

**TAGLIO DA UTILIZZARE PER ASPORTO DEL PEZZO TRATTEGGIATO, E UTILIZZO DEL TAVOLO A :**  
**H min 825 mm - H max 880 mm**  
**USE THE DOTTED LINE TO REMOVE THE EXTRA LENGTH:**  
**H min 825 mm - H max 880 mm**  
**COUPURE PIÈCE POINTILLÉ POUR UTILISATION DU TABLE**  
**À : H min 825 mm - H max 880 mm**

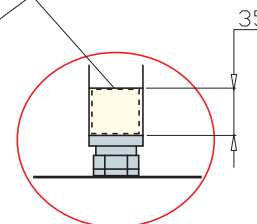

**PART.A**

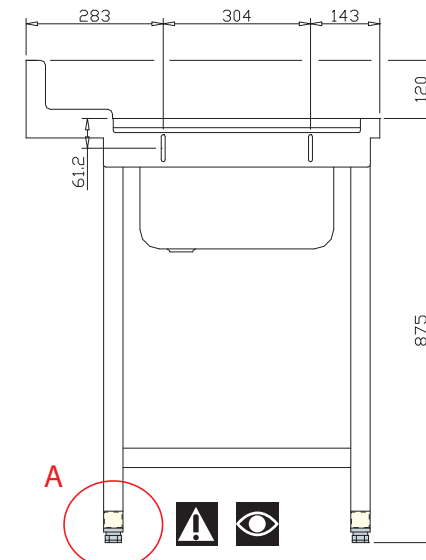
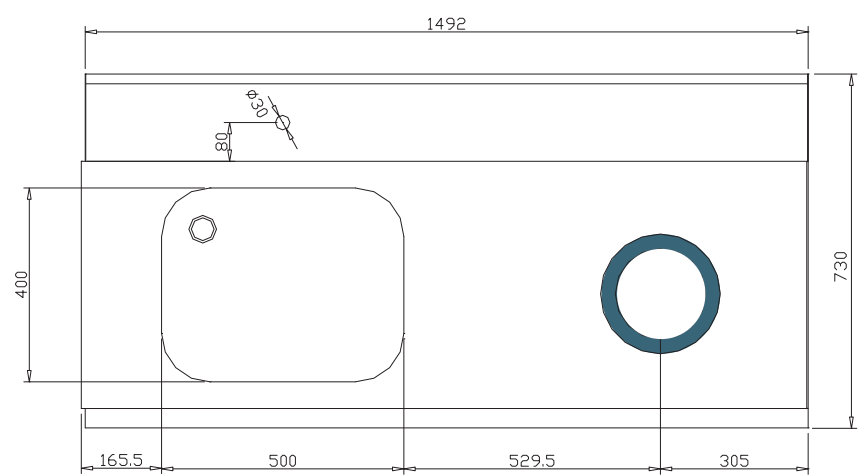

**ALTEZZA DI LAVORO PER SCORRIMENTO CESTO: H min 860 - H max 915 mm**  
**USEFUL WORKING HEIGHT TO SLIDE BASKET: H min 860 - H max 915 mm**  
**HAUTEUR GLISSEMENT PANIER: H min 860 - H max 915 mm**





**DISEGNO VALIDO PER VERSIONE DESTRO / SINISTRO**  
**DESIGN VALID FOR EITHER RIGTH OR LEFT VERSION**

	Cod.interno / File : T-80 DX
	Scala : ---
	Disegnatore : AS
	Data : 08/03/2016
	Rev. : 0.0
	Tavola : 1/1

Le informazioni contenute nel presente documento corrispondono alla definizione sul prodotto alla data di emissione dello stesso.  
 The manufacter reserves the right to make alterations to the product without notice.