



TAGLIO DA UTILIZZARE  
PER ASPORTO DEL PEZZO  
TRATTEGGIATO, E UTILIZZO  
DEL TAVOLO A :

H min 825 mm - H max 880 mm

USE THE DOTTED LINE TO  
REMOVE THE EXTRA LENGHT:

H min 825 mm - H max 880 mm

COUPURE PIÈCE POINTILLÉ  
POUR UTILISATION DU TABLE

À : H min 825 mm - H max 880 mm

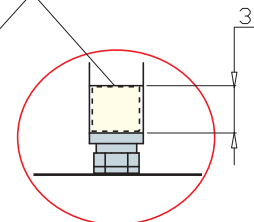

PART.A

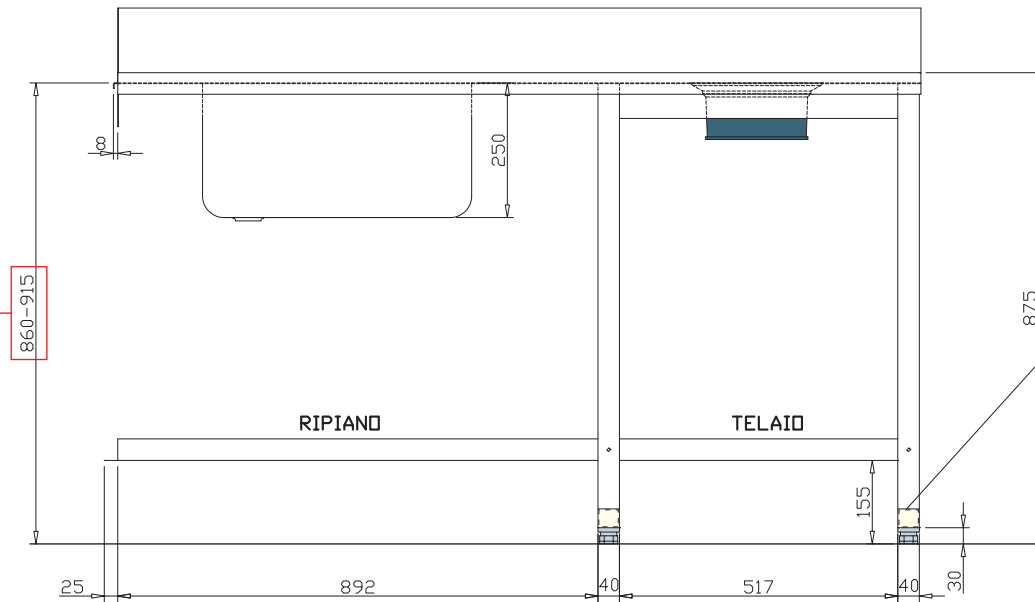
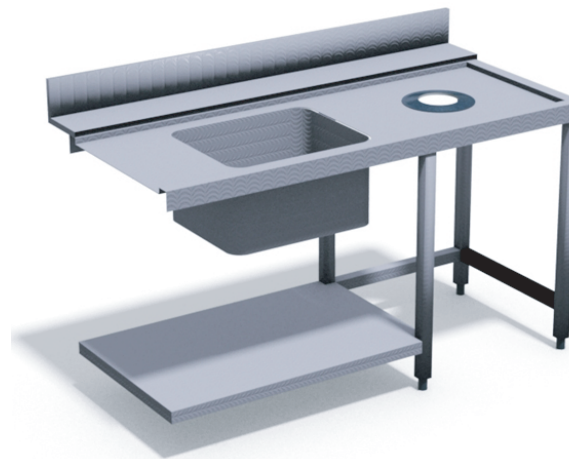
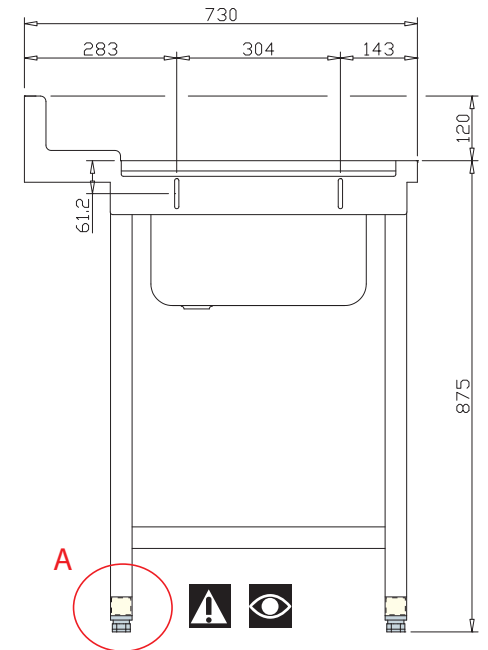

ALTEZZA DI LAVORO PER SCORRIMENTO CESTO: H min 860 - H max 915 mm

USEFUL WORKING HEIGHT TO SLIDE BASKET: H min 860 - H max 915 mm

HAUTEUR GLISSEMENT PANIER: H min 860 - H max 915 mm

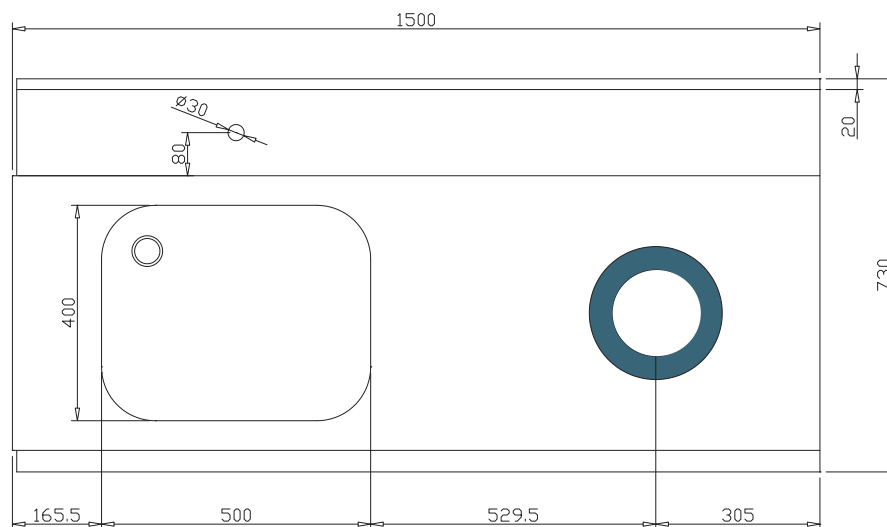

DISEGNO VALIDO PER VERSIONE DESTRO / SINISTRO  
DESIGN VALID FOR EITHER RIGTH OR LEFT VERSION

	Cod.interno / File : T-80 E DX
	Scala : ---
	Disegnatore : AS
	Data : 08/03/2016
	Rev. : 0.0
	Tavola : 1/1

Le informazioni contenute nel presente documento corrispondono alla definizione sul prodotto alla data di emissione dello stesso.  
The manufacter reserves the right to make alterations to the product without notice.